

Informationen Information

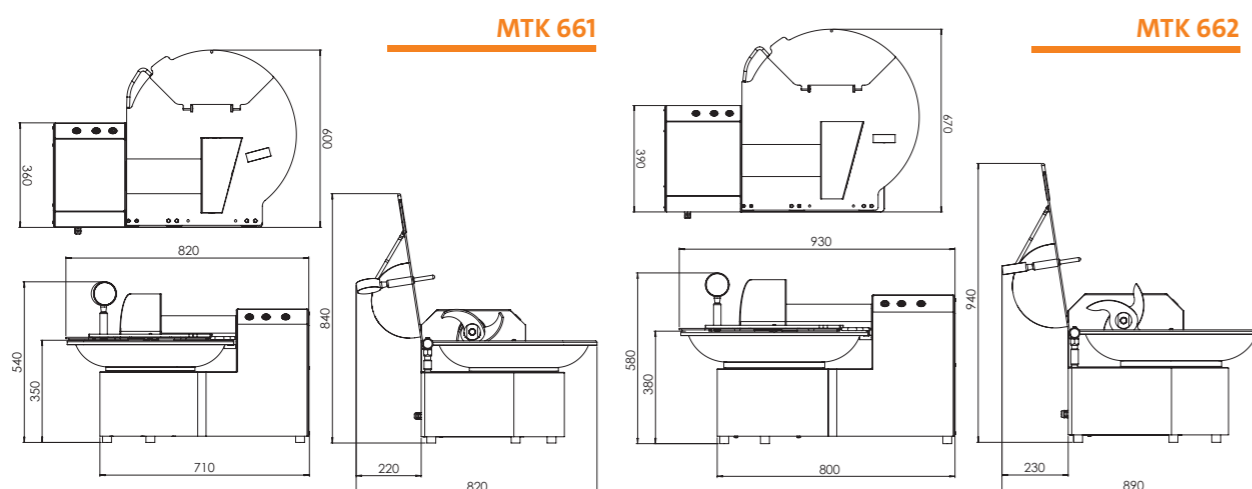

MSK 760 H II

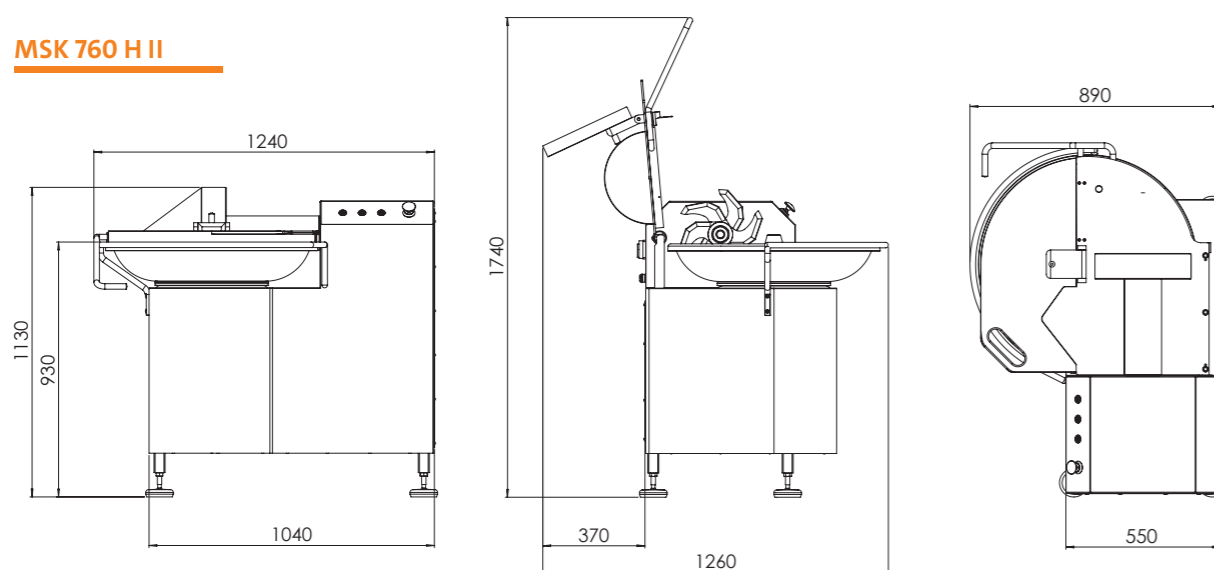

Maßangaben in mm / Dimensions in mm

	MTK 661	MTK 662	MSK 760 H II
Motorspannung / Motor voltage	400 V, 50 Hz, Drehstrom 400 V, 50 Hz, 3-phase AC	400 V, 50 Hz, Drehstrom 400 V, 50 Hz, 3-phase AC	400 V, 50 Hz, Drehstrom 400 V, 50 Hz, 3-phase AC
Absicherung / Fuse protection	16 A träge / inert	16 A träge / inert	32 A träge / inert
Motorleistung / Motor capacity	1,7 / 2,2 kW	3,2 / 4,0 kW	9,5 / 11,0 kW
Messerkopf / Knife head	3er / pcs	4er / pcs	6er / pcs
Messerwellendrehzahl / Knife shaft speed	1400 / 2800 U/min / r.p.m.	1400 / 2800 U/min / r.p.m.	1750 / 3500 U/min / r.p.m.
Schüsseldrehzahl / Bowl speed	12 / 24 U/min / r.p.m.	12 / 24 U/min / r.p.m.	12 / 24 U/min / r.p.m.
Schüsselinhalt / Bowl capacity	ca. / approx. 13 Liter / litres	ca. / approx. 20 Liter / litres	ca. / approx. 35 Liter / litres
Gewicht / Weight	ca. / approx. 130 kg	ca. / approx. 160 kg	ca. / approx. 430 kg

Änderungen vorbehalten / Subject to change

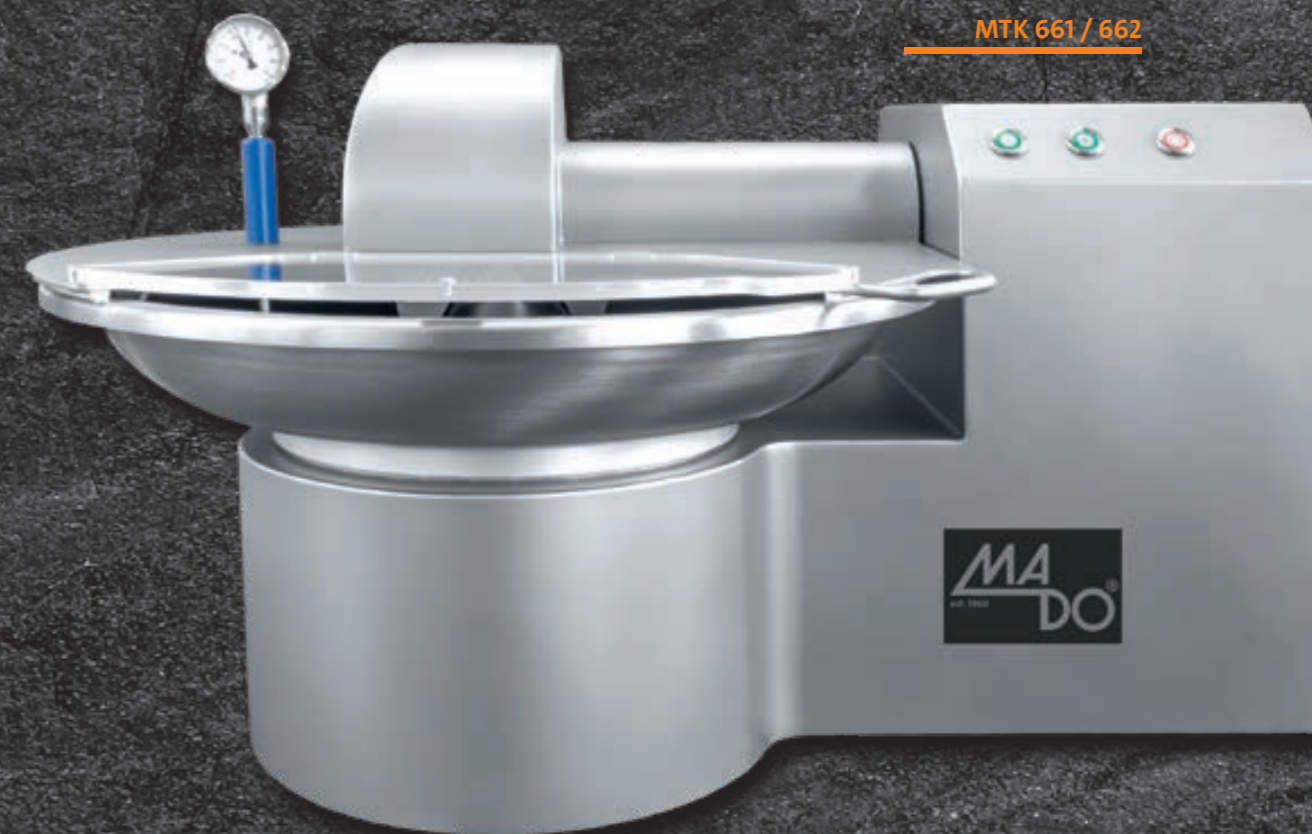

MTK 661 / 662

KUTTER CUTTER

MTK 661 / 662, MSK 760 H II



Kutter



Cutter

Die MADO Kutter MTK 661 / 662, MSK 760 H II mit einem Schüsselinhalt von 13, 20 und 35 Liter sind optimal für kleinere Chargen.

Das von allen Seiten geschlossene Maschinengehäuse komplett aus Edelstahl gefertigt, gewährleistet eine hohe Langlebigkeit.

Serienausstattung:

- Allseitig geschlossenes Maschinengehäuse
- Maschinenkörper, alle Funktionselemente und Schüssel aus rostfreiem Edelstahl
- Zwei Geschwindigkeitsstufen
- Messerkopf abnehmbar
- Motorbremse
- Analoges Thermometer (Messbereich -10 °C bis + 70 °C)

Optionen:

- Thermometer digital mit Temperaturabschaltung
- Untergestell fahrbar (MTK 661 / 662)
- 3er Messerkopf (MSK 760 H II)

MTK 662



MIT THERMOMETER DIGITAL
WITH DIGITAL THERMOMETER



MIT THERMOMETER DIGITAL UND
MIT UNTERGESTELL FAHRBAR
WITH DIGITAL THERMOMETER
AND WITH MOVABLE FRAME

The MADO Cutter MTK 661 / 662, MSK 760 H II with a bowl capacity of 13, 20 and 35 litres are optimal for small batches.

A complete closed machine housing made of stainless steel, guarantees a high longevity.

Basic version:

- Completely closed machine housing
- Machine body, all functional parts and bowl made of stainless steel
- Two speed levels
- Removable knife head
- Motor brake
- Analog thermometer (Range -10 °C to + 70 °C)

Options:

- Digital thermometer with temperature termination
- Movable frame (MTK 661 / 662)
- 3-pcs knife head (MSK 760 H II)

MTK 661



MSK 760 H II

